



Solutions in Aviation Fuel Analyses Using Gas Chromatography

**Erwin Barendregt (Application Engineer), Rik Suijker (Application Engineer),
Rob de Jong (Product Manager Chromatography) - PAC L.P. | AC Analytical Controls B.V.**

PAC Headquarters: 8824 Fallbrook Drive | Houston, Texas 77064, USA | T: +1 800.444.TEST or +1 (281) 940 1803 | F: +1 (281) 580 0719
AC Analytical Controls B.V. : Innsbruckweg 35 | 3047 AG Rotterdam | The Netherlands | T: +31 (10) 4624 811 | F: +31 (10) 4626 330
E-mail: sales@pacpl.com | Web: www.pacpl.com

Commercial jet fuel is a high-quality fuel, but if it fails to meet this required purity and other quality tests for use on jet aircraft, it is commonly sold to other ground-based users with less demanding requirements, meaning a loss of profit. With over \$50 Billion spent on Aviation fuel per year, lab and process chemists are faced with a variety of challenges in their quality control process. For two of those specific analytical challenges new solutions based on gas chromatography (GC) are presented.

FAME Contamination In Aviation Turbine Fuel (AVTUR)

It is now common for national governments to mandate the use of renewable components in automotive fuels. One of the most common options is to blend Fatty Acid Methyl Ester (FAME) into diesel to produce what is often called 'biodiesel'. Biodiesel is designated B5 when it contains 5% FAME. Pure FAME is often designated B100.

The introduction of FAME into diesel fuel created some issues with an impact on Aviation Turbine Fuel:

- FAME components are surface active and tend to stick to metal or glass surfaces. Where supply chains handle both jet fuel and biodiesel this property brings the risk of cross contamination
- FAME is a non-hydrocarbon fuel component. The jet fuel specification states explicitly that only hydrocarbon components or approved additives are allowed.

The international jet fuel specifications (e.g. DEF STAN 91-91) limit FAME content to less than 5 mg/kg (ppm w/w). Levels above 5 mg/kg render the fuel off-specification. This is a serious issue because there have been instances in which jet fuel containing more than 5 ppm FAME has inadvertently been supplied to the airport.

A reliable and rugged means of measuring FAME content in jet fuels is required to ensure compliance to the 5 mg/kg specification. Multi-dimensional GC using Deans switching and refocusing technology supplies such a means, and forms a very suitable alternative to existing LC-, GC/GC-, GC/MS- and SPE/GC- techniques for its lower cost, ease of use, robustness and lack of sample pretreatment.

The FAME components determined using this multi-dimensional GC heart-cut method are listed in table 1 below. These components have been specifically chosen as they typically make up greater than 95% of the composition of the major biofuel vegetable oil feeds currently used in biodiesel blends with conventional mineral diesel.

FAME	Molecular Formula	Symbol Used
methyl hexadecanoate (methyl palmitate)	C17H34O2	C16:0
methyl octadecanoate (methyl stearate)	C19H38O2	C18:0
methyl octadecenoate (methyl oleate)	C19H36O2	C18:1
methyl octadecadienoate (linoleate)	C19H34O2	C18:2
methyl octadecatrienoate (linolenate)	C19H32O2	C18:3

Table 1: Typical FAME Components in Biodiesel

Analysis Description

A test portion of AVTUR is run neat on a multi-dimensional gas-chromatographic system that accommodates both Deans-switching and refocusing technology. A pre-separation of the sample takes place on a nonpolar 1st dimension column. After 1st dimension separation the FAME species of interest are transferred towards a highly polar 2nd dimension column by performing a heart-cut using Deans-switching. Before final separation the FAME species are refocused on the first part of the 2nd dimension column by using temperature-based trapping. When the last specified FAME component (C18:0) has eluted from the 1st dimension column the GC is set towards optimum flow and temperature conditions for the 2nd dimension column. When these conditions have been established the trapping of the FAME species is stopped,

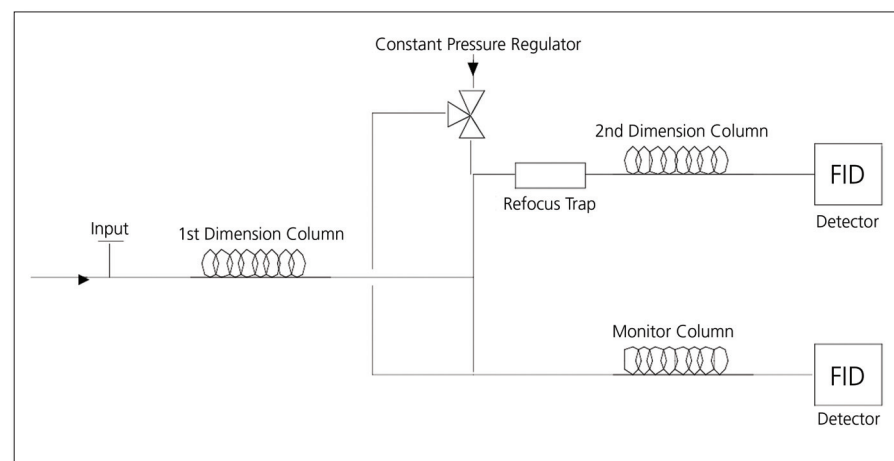

Figure 1: FAME in AVTUR System Plumbing Diagram

introducing/injecting them onto the 2nd dimension column. There they are separated from each other and the remaining matrix. A flame-ionisation detector (FID) is used for quantification by reference to an external standard of the specified FAME species in a FAME-free AVTUR fuel.

Analysis Results

Excellent results were obtained for retention time stability, peak area stability, sensitivity and linear behavior. The standard quantification range of 2 -50 mg/kg can be shifted towards a range of 10 - 150 mg/kg by simply changing injection volume. Figure 2 show chromatogram overlays and Retention Time stability. With a maximum variation of 0.02% in Retention time, identification of FAME components is clearly unambiguous.

Figure 4 represents data for a representative Jet fuel sample. Even at the very low level of 6.6 ppm w/w FAME for this particular sample, the repeatability for the method is only 2.8% (n=10). Even C18:0, found at a concentration of 0.75 ppm w/w has a more than acceptable repeatability at 3.4% RSD.

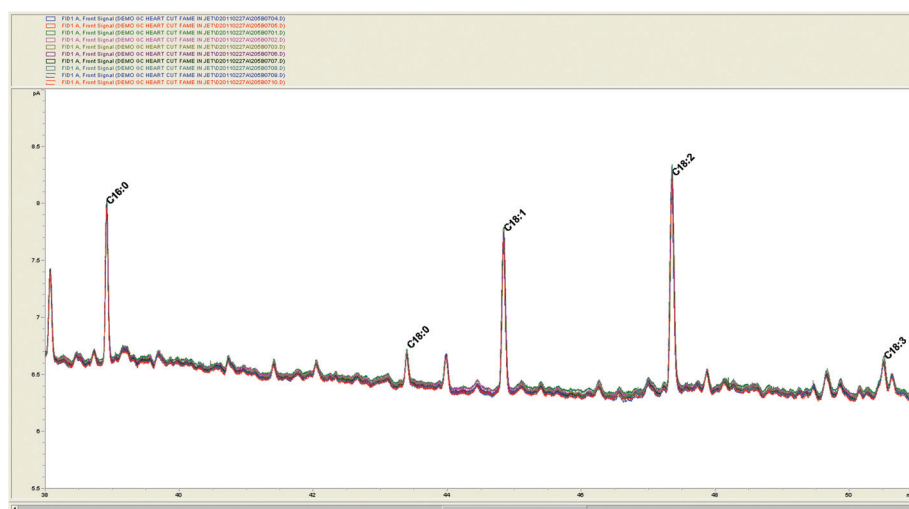

Figure 2: Overlay of 10 chromatograms

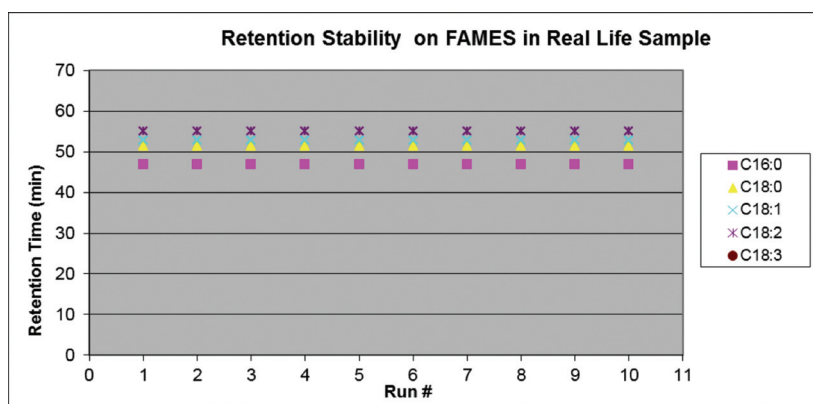

Figure 3: Retention Time Stability for individual FAME components

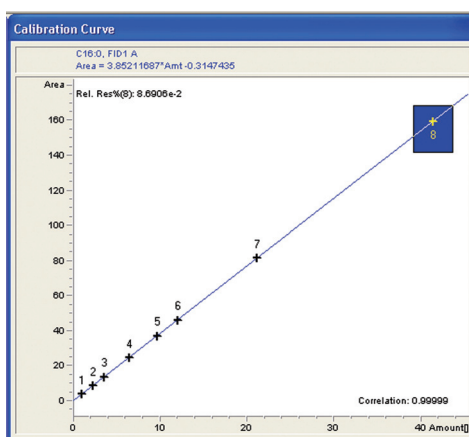

Figure 6: Calibration plot C16:0 1-50 mg/kg

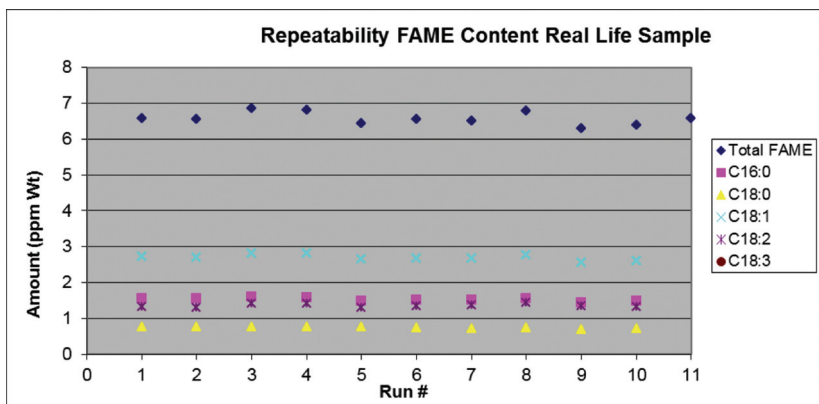

Figure 4: Result Repeatability for individual and single component FAME

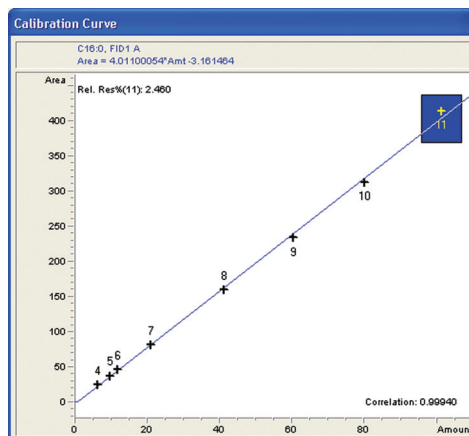

Figure 7: Calibration Plot C16:0 10-100 mg/kg

The method developed has sensitivity of better than 0.5ppm w/w per FAME component or 2 mg/kg total FAME. Figure 5 shows a 1 ppm per component in jet fuel.

The Linear Dynamic Range for the method was tested for C16:0 in two concentration ranges. Figure 6 and 7 show calibration plots for 1 – 50 mg/kg and from 10 - 100 mg/kg.

Both ranges show correlation better than 0.999 over the complete range.

Conclusion

Above results demonstrate that the newly developed analysis technique based on 2 dimensional GC is a powerful, robust and accurate method for determining trace levels FAME contamination in aviation turbine fuels.

It allows both individual and total FAME to be analysed. The Quantification Range for total FAME is 2-50 mg/kg, complying with DEFSTAN 91-91 specifications for the analysis of FAME in AVTUR (soon to be incorporated into ASTM D1655).

An extension of the methods range to 10-150 mg/kg is optional to make the system also useful for anticipated future specifications.

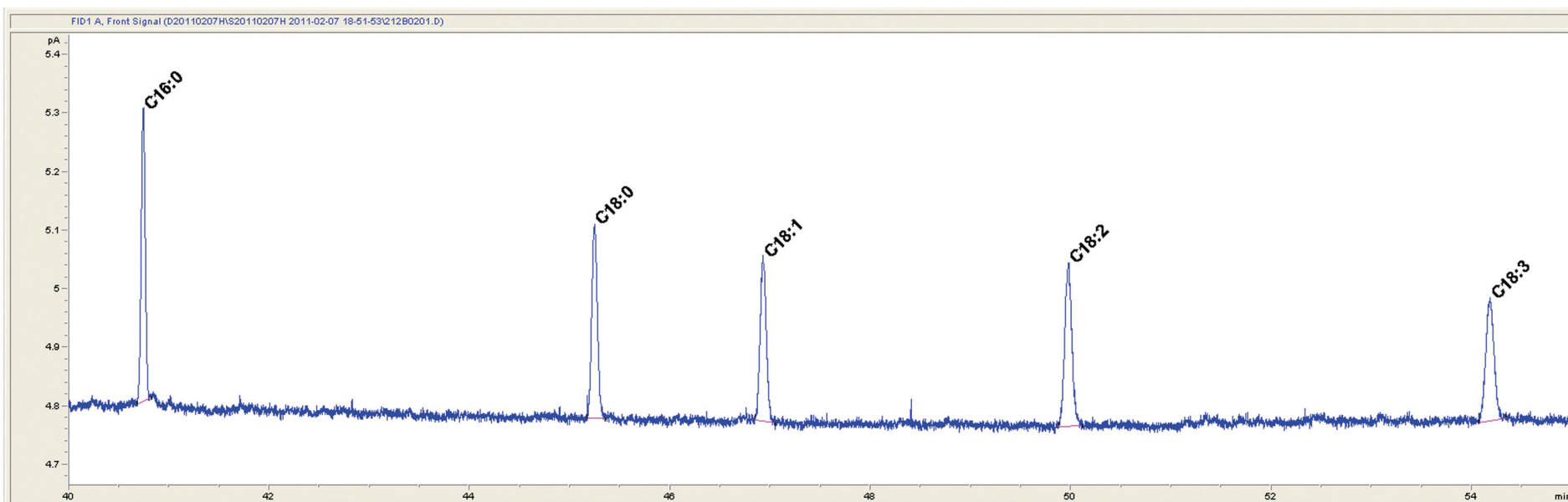

Figure 5: Sensitivity of the method: 1 ppm of individual FAME components

PNA-Analysis In Jetfuel

The PNA in jet fuel analyzer is based on a well-established multi-dimensional column switching technique. After sample introduction, a set of columns and traps separates the sample into different hydrocarbon groups. The multi-dimensional technique determines carbon number distribution of each group: Paraffins, Naphthenes and Aromatics.

Although made up of many different hydrocarbons, jet fuels consist essentially of four general types of compounds: paraffins (including isoparaffins), cycloparaffins or naphthenes, aromatics, and very low concentrations of olefins. The proportion of each compound type varies with the different types of crude oils and the processing needed to produce the fuel. A typical fuel will contain hundreds of different compounds. In general, paraffins offer the most desirable combustion cleanliness characteristics for jet fuels. Naphthenes are the next most desirable hydrocarbons for this use. Although olefins generally have good combustion characteristics, their poor gum stability usually limits their use in aircraft turbine fuels to about 1% by volume or less. Aromatics generally have the least desirable combustion characteristics for aircraft turbine fuel. In aircraft turbines they tend to burn with a smoky flame and release a greater proportion of their chemical energy as undesirable thermal radiation than the other hydrocarbons. Thus, Jet fuel is limited to 25% maximum aromatics by volume.

Therefore it is necessary to have a reliable analysis method for determining Aromatics (content specified in ASTM D1655, Def. Stan 91-91, JIG, Energy Institute etc.), Paraffins and Napthenes in aviation turbine fuels. Currently the "Fluorescent Indicator Adsorption" method (FIA), ASTM D1319 is widely used to determine the aromatic content. This method however, is very labour intense, has a relatively high cost per sample and generally exhibits poor reproducibility.

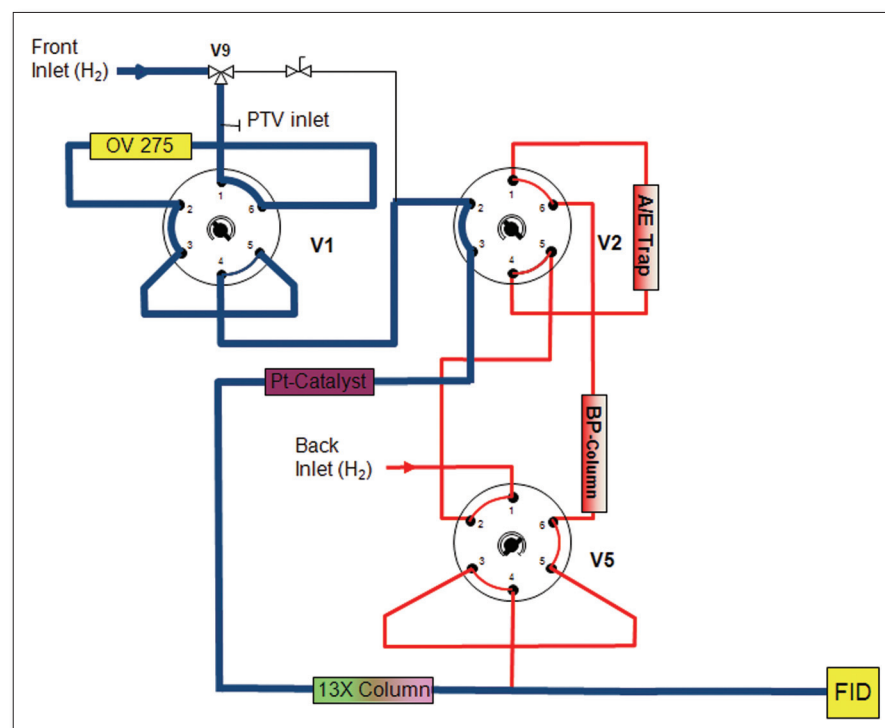

Figure 8: PNA in Jetfuel System schematics

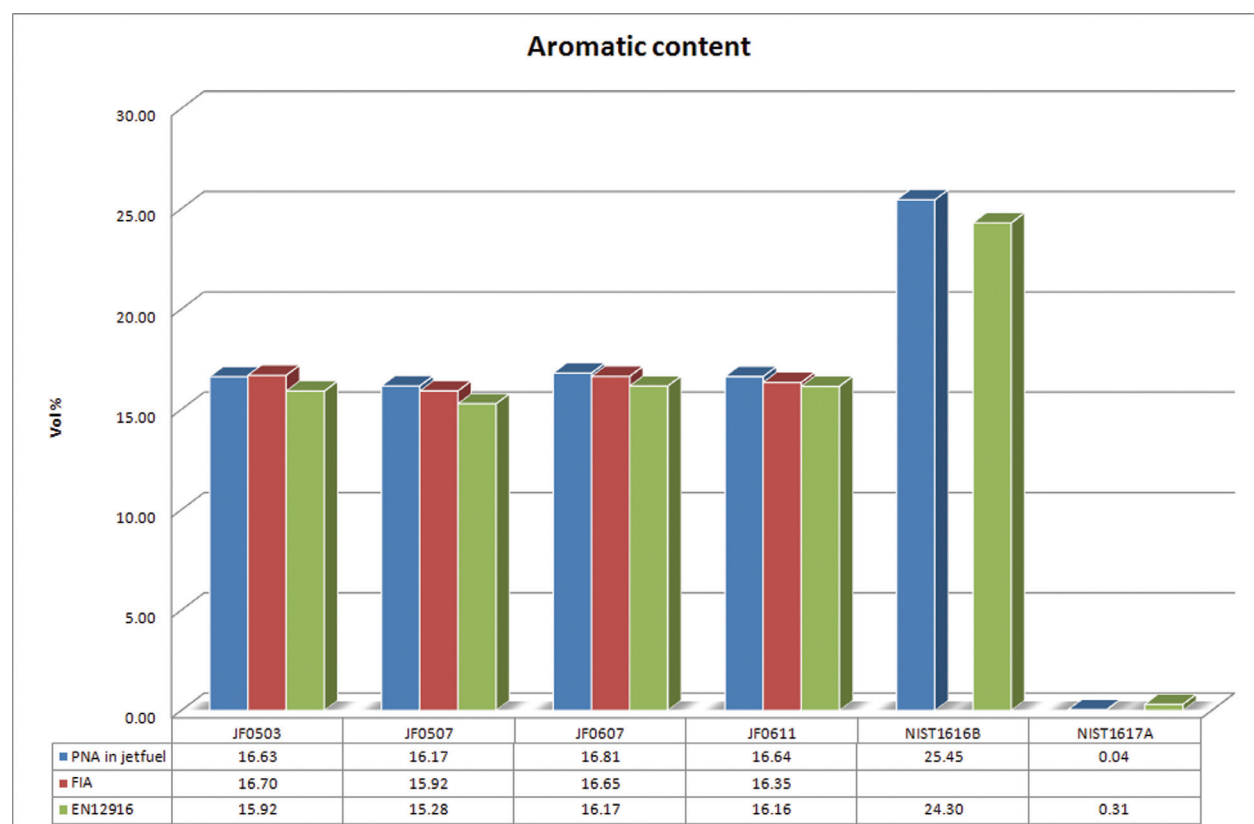

Figure 9 Figure 8: Comparison of methods: Existing methods ASTM D1319/IP156 (FIA) in red, IP391 / EN12916 (MDA) in green vs. 'PNA in jet fuel' method in blue. Note that results for IP391 / EN12916 are corrected to vol% for comparison

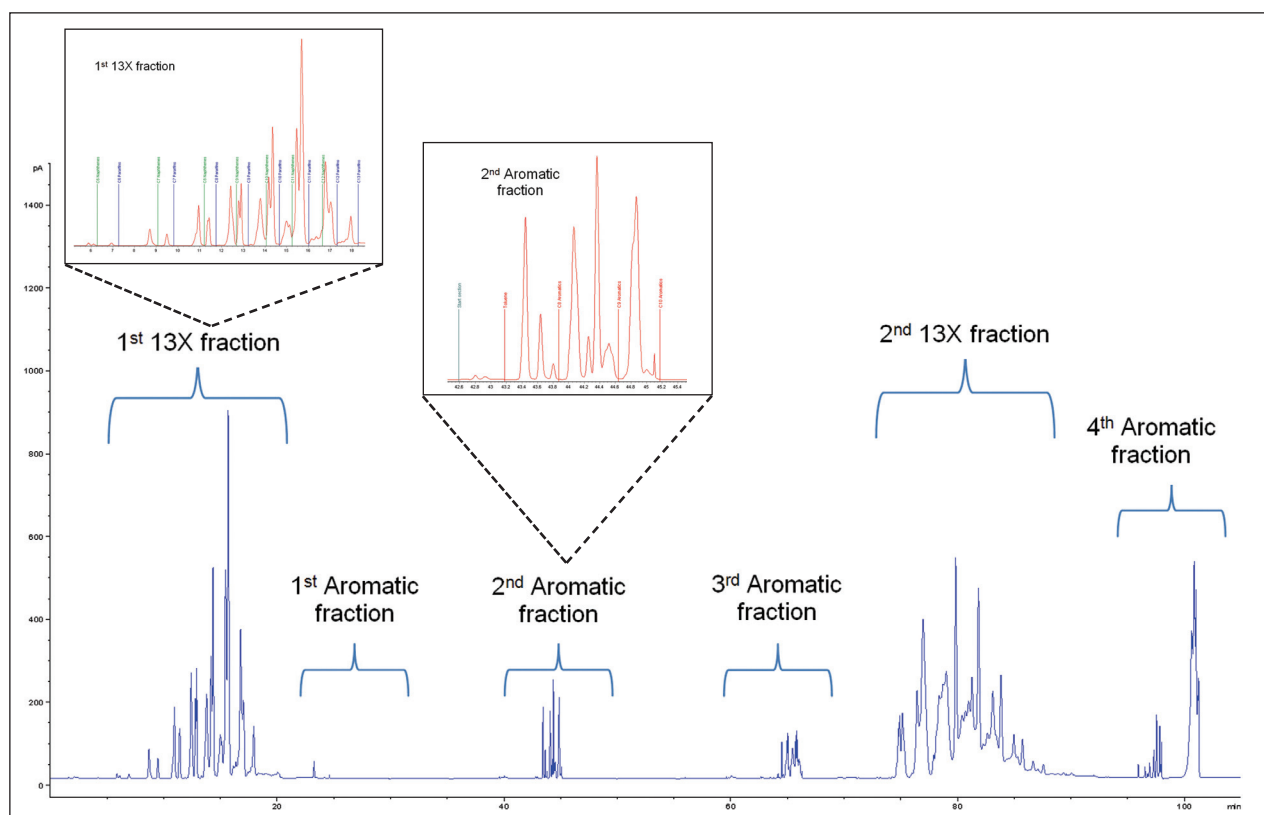

Figure 10: Example chromatogram Jet fuel sample JF0611. Enlarged sections show 1st 13X fraction and 2nd aromatic fraction

Analysis Description

A small portion of the sample is injected by an autosampler into the AC PTV inlet of the GC. A pre-separation takes place on a polar column to separate aromatics from aliphatic components for the 1st part of the sample. The non-aromatics (until C12) are further separated on a dedicated 13X column to separate paraffins from naphthenes on carbon number. The remaining sample is divided into different aromatic / non aromatic fractions by a dedicated trap and capillary column. The aromatics are further separated on the capillary column by boiling point and detected by the FID. The non-aromatics are collected by backflush and trapped on the 13X column. The 13X column is ramped to a temperature above 500 °C to separate the heavy part of the aliphatics by carbon number.

Analysis Results

Different batches of jet fuel (ASTM round robin samples and NIST standard reference material) have been analysed by the PNA in jet fuel analyser. A comparison is made with the widely used FIA ASTM D1319 and Mid Distillates Analysis (MDA) IP391/EN12916 on high performance liquid chromatography (HPLC) method (figure 9) for the total aromatic content.

The PNA in jet fuel analyser shows excellent recoveries compared with the FIA and HPLC method. Besides the total aromatics, Benzene, Toluene, C8, C9, C10 and C11+ aromatics can be separately reported by the PNA software.

Non aromatics are well separated in Naphtenes and Paraffins for the range C5-C12. Because of the high count of isomers for higher carbon numbers, the separation up to C18 is based on Carbon number distribution, and result is reported as C13-18 Saturates.

Conclusion

An alternative method for determination of PNA in Aviation Fuel has been developed.

The System is characterised by the use of very robust column switching techniques with proven track record. Results demonstrate excellent stability and analytical performance comparable to existing methods ASTM D1319/IP156, IP391 and EN 12916.

While these innovative GC-techniques do not involve any sample preparation, and require no GC*GC software or MS or LC-detector hardware, they are easy to implement in the lab.